

Please read and save these instructions. Read carefully before attempting to assemble, install, operate or maintain the product described. Protect yourself and others by observing all safety information. Failure to comply with instructions could result in personal injury and/or property damage! Retain instructions for future reference.

DynaQuip® Controls MA Series Electric Actuator

Features

- 30% Duty cycle at ambient temperature and rated torque
- Thermal overload protection to guard motor against overheating
- Manual overrides on all standard models
- Rotates clockwise to close valve and counterclockwise to open valve
- Mechanical dial position indicator
- Self-locking gearing

⚠ WARNING Do not apply electric power unless unit is fully assembled and mounted.

Always disconnect electric power source and relieve pressure in the system before working on this unit.

It is recommended that eye protection be worn while servicing the system.

Failure to comply with above warnings could result in personal injury and/or damage to the unit.

Manual Override

In the event of power failure, the DynaQuip actuator may be cycled manually. Handwheel manual override is always engaged. Actuators rotate clockwise to close valve and counterclockwise to open valve. Failure to rotate in the proper direction will cause limit switches to malfunction.

Inspection Upon Receipt

1. Visually inspect to be sure actuator has not been damaged in transit.
2. Verify that Model Number is correct as ordered.
3. Verify that electrical supply voltage is the same as specified on the actuator label.
4. Verify that NEMA rating on label is as required: Weatherproof/Corrosion Resistant (NEMA 4).
5. Check that mounting bolt pattern and output shaft/adaptor configurations are as required.

6. Turn handwheel to be certain that manual override and position indicator are in working condition and have not been damaged in transit.

Installation

1. Before mounting actuator, verify that the torque requirement is less than the output torque of the actuator.
2. Check that output shaft adapter fits stem of valve or damper before inserting into actuator.
3. Insert output shaft adapter into actuator. Make sure fit is satisfactory.
4. Determine that actuator position, open or closed, matches position of equipment with which it is to be mounted. Use manual override to change position, if necessary.
5. Mount to top plate of valve, valve bracket or damper. Be sure that base of actuator is flush with top plate.
6. Insert bolts but do not tighten.
7. Use manual override to move stem of valve or damper slightly to correct side thrust or misalignment.
8. Manually place valve in either full stroke position.
9. Tighten bolts using a cross pattern and equally drawing bolts down to finish.

Electrical Installation

Verify that the electrical supply voltage is the same as required actuator voltage.



Follow wiring diagram below. Use the wiring diagram inside actuator cover for voltages other than 115VAC.

NOTE: Electric power to terminals 1 & 3 will cause the camshaft to rotate counterclockwise.

Electric power to terminals 1 & 4 will cause the camshaft to rotate clockwise.

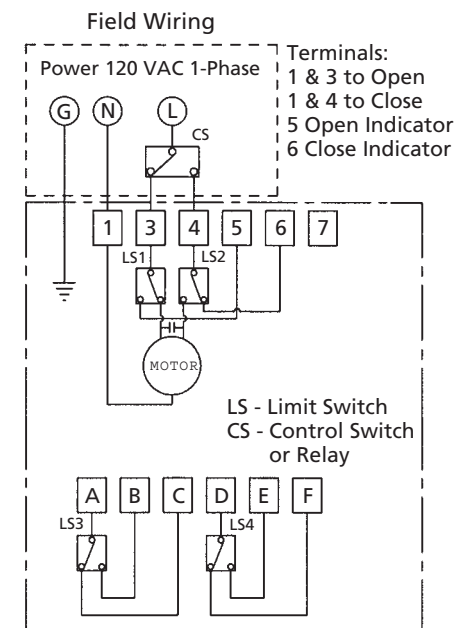

**DynaQuip Controls
MA Series Actuator**

DynaQuip® Controls MA Series Electric Actuator

Travel Stop Adjustment

At the base of the DynaQuip Controls MA series electric are two (2) adjustable travel stops.

1. Facing the actuator, with housing vertical, the adjustable bolt to the left controls CCW movement (valve open). The bolt to the right controls CW movement (valve close).
2. Loosen both adjustable stops so that full travel in either direction will not engage them.
3. After mounting and tightening actuator to valve use manual override to drive valve to the fully closed position.
4. Tighten the adjustable stop bolt on the right side until it engages the stop. Back the bolt off one-half turn. Tighten nut.
5. Follow same procedure in item 4 after fully opening the valve.

Cam Adjustment

The cams are preset at the factory. When additional adjustments are needed, follow steps described below.

- LS4 - Sets with LS2
- LS3 - Sets with LS1
- LS2 - Close
- LS1 - Open

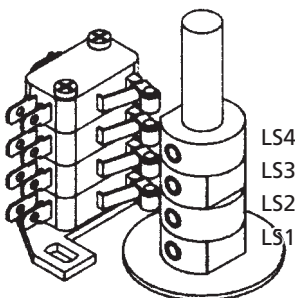

TO SET OPEN POSITION

1. Turn power off.
2. Use manual override to turn valve to the fully open position.
3. With the power turned off, remove cover, loosen set screw in the bottom cam. This cam controls the open position.
4. Rotate cam clockwise into the switch.
5. Slowly rotate cam counterclockwise until you hear a light click. Tighten set screw.
6. Reinstall cover and turn power back on.

TO SET CLOSED POSITION

1. Turn power off.
2. Use manual override to turn valve to the fully closed position.
3. With the power turned off, remove cover, loosen set screw in the second from bottom cam. This cam controls the closed position.
4. Rotate cam counterclockwise into switch.
5. Slowly rotate cam clockwise until you hear a light click. Tighten set screw.
6. Reinstall cover and turn power back on.

Maintenance

Under normal operation, DynaQuip electric actuators require no formal maintenance program.

Regularly scheduled inspections should be performed, to check:

- Actuator-to-valve alignment
- Damaged housing or mounting hardware
- Worn, loose or shifted parts due to shock, vibration, etc.

STORAGE

Store in climate controlled environment to prevent condensation. If stored outdoors internal heaters must be installed and functioning.

Note: After Installation it is the customers responsibility to be certain that all set screws, terminal screws, housing bolts and mounting bolts are tight and that all limit switches, potentiometers and position transmitters are calibrated to the individual settings required for their specific application. See back cover for modulating control interface instructions.

MA SERIES

Troubleshooting Chart

Problem	Cause / Corrective Action
Actuator Stops Operating	<ul style="list-style-type: none"> • Interrupted power. Check for broken or loose wires. Blown fuses or tripped breaker. Check switches. • Tripped thermal overload caused by overheating (see overheating below). • Motor burnout. Check to insure that correct voltage type is in use. Check all wiring against installation wiring diagrams. • Malfunctioning valve. Check to insure that valve is operating properly.
Overheating	<ul style="list-style-type: none"> • Excessive duty cycle. Check duty cycle (frequency of operation). DynaQuip electric actuators have a duty cycle of 30% (actuator is energized no more than 30% of the time). • Low voltage "brown out". Measure line voltage to insure that actuator is receiving full rated voltage. • Ambient temperature too high and/or heat being conducted through mounting hardware. • Motor stall. Check for foreign obstruction. Check valve for proper operation. Check for increased torque load due to line pressure, etc.
Low Torque Output	<ul style="list-style-type: none"> • Low voltage or current. Check to insure that power supply is within listed specifications. • Overheating. See overheating above.
Incorrect Travel or Operation	<ul style="list-style-type: none"> • Refer to "Cam Adjustment" in this manual. • Circuit not energized for full duration of cycle. Malfunction in control device (relay, switch, etc.), inspect and correct or replace. • Out of phase for three phase actuators. Switch two incoming power leads.

Safety First

In the maintenance and operation of mechanical equipment, safety is a basic factor that must be considered at all times. By using proper clothing, tools and procedures, serious accidents to you and your fellow workers can be prevented.

After inspecting the actuator keep the following information for future reference.

Electric Actuator Model Number _____

Output Torque _____

Voltage _____

Serial Number _____

Date of Installation _____

Location _____

Valve / Line Tag Number _____

DynaQuip® Controls MA Series Electric Actuator

Modulating Control Board; Interface

TURN POWER OFF BEFORE CHANGING ANY SETTINGS

Instrument Input Signal, Output Signal and Failure Mode Selection

The selection of "input signal", "output signal" and "failure mode" is determined by "Dip Switches" S1 to S8.

Instrument Input Signal Selection

- A) 4 - 20 mA: Set 1 "ON" / 2 "OFF"
- B) 2 - 10 VDC : Set 1 "OFF" / 2 "ON"
- C) 1 - 5 VDC : Set 1 "OFF" / 2 "OFF"

Output Signal Position Transmission Signal

- A) 4 - 20 mA: Set 3 "OFF" / 4 "ON" / 5 "OFF"
- B) 2 - 10 VDC : Set 3 "ON" / 4 "OFF" / 5 "ON"

Valve Position at Signal Input

- A) Fully "Closed" at 4 mA, 2 V or 1 V and fully "Open" at 20 mA, 10 V, or 5 V : Set 6 "OFF"
- B) Fully "Closed" at 20 mA, 10 V or 5 V and fully "Open" at 4 mA, 2 V, or 1 V : set 6 "ON"

Valve Position upon Loss of Instrument Signal

- A) Valve stays in "LAST POSITION" when 4 mA (2 V or 1 V) is "Fully Closed" : Set 7 "ON" / 8 "ON"
- B) Valve moves to "Closed" when 4 mA (2 V or 1 V) is "Fully Closed" : Set 7 "OFF" / 8 "ON"
- C) Valve moves to "Open" when 4 mA (2 V or 1 V) is "Fully Closed" : Set 7 "ON" / 8 "OFF"
- A) Valve stays in "LAST POSITION" when 20 mA (10 V or 5 V) is "Fully Closed" : Set 7 "ON" / 8 "ON"
- B) Valve moves to "Closed" when 20 mA (10 V or 5 V) is "Fully Closed" : Set 7 "ON" / 8 "OFF"
- C) Valve moves to "Open" when 20 mA (10 V or 5 V) is "Fully Closed" : Set 7 "OFF" / 8 "ON"

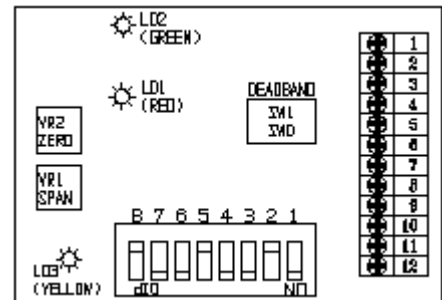

ZERO & SPAN ADJUSTMENT

Zero (VR2)

- A) Place actuator in full clockwise position.
- B) Input signal (4 mA, 2 V, or 1 V).
- C) Turn VR2 in a counterclockwise direction until RED LIGHT remains ON.

SPAN (VR1)

- A) Place Actuator in full counterclockwise position.
- B) Input signal (20 mA, 10 V, or 5 V).
- C) Turn VR1 in a clockwise direction until the GREEN LIGHT remains ON.

DEADBAND ADJUSTMENT

Deadband (SW1 - SW0 adjust sensitivity to input signals)

- A) Greatest sensitivity is with switch "1" (0 - 90° is divided into 80 set points)
- B) Least sensitivity is with switch at "0". (17 set points)

(Each selected number after "1" drops the number of inputs by 17 from the previous setting.)
(Setting 2 would have 63 set points, etc.)

Thank you for selecting DynaQuip electric actuators for your valve automation requirements.