

# DynaQuip Smart SV17 Data Sheet

**The Smart SV17** is a truly smart electric actuator designed to cover a wide range of functional applications. It is fully electronic using digital magnetic positioning and entirely run by firmware. The smart version is recognisable by the introduction of a bright OLED screen and external push buttons that are used to set and adjust the SV17 Smart actuator. Available in ON OFF, Modulating, Failsafe, Hi-Speed, Failsafe Modulating & Hi-Speed Modulating. Standard features include:



- OLED Screen ● User friendly local button controls ● Brushless motors
- Anti-condensation heater ● Electronic torque limiter ● Many functional options

## Smart Specifications

Smart Specifications	SV17
Max Rated torque Nm output (in./lbs.)	Break 221 in./lbs. / Run 177 in./lbs.
Voltage range	24VDC, 24VAC, 12VDC, 110VAC, 220VAC
Mounting (ISO5211) x drive (female octagon)	F03, F04 & F05 x 14mm
Ingress Protection	IP67
Electrical connection	Pre-wired multi-core 2.6ft. cable
End of travel confirmation (dry contact/volt-free)	2 x Electronic relays
Local visual position indicator	Dome style
Housing material	ABS (Aluminum option)
Weight ABS (Aluminum)	1.7lbs.

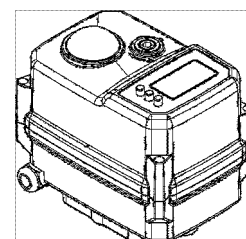
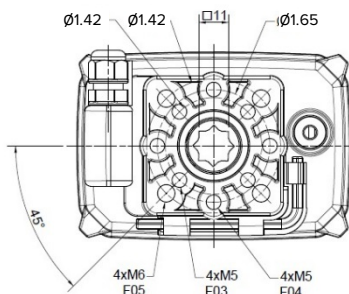
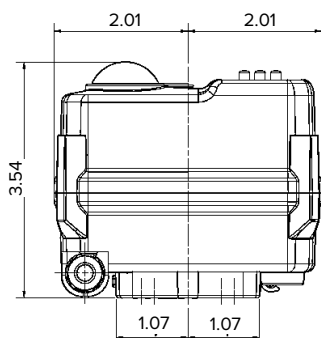
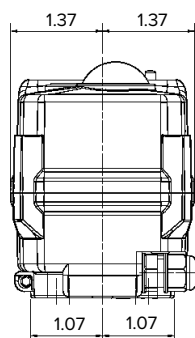

## DynaQuip SV17 Data Sheet On-Off and Failsafe

### Model: SV17 SMART ON-OFF & SV17 FAILSAFE ELECTRIC ACTUATORS

Specification	High Voltage	Low Voltage	
Rated Voltage	95-265VAC	24VAC/DC	DC12V
Voltage Range	AC 95-265V 50/60Hz DC 100-300V	AC 22-28V 50/60Hz, DC 22-28V	DC 10-15V
Consumption On/Off	9.6W run, 0.12W hold	9.6W run, 0.85W hold	9.6W run, 0.85W hold
Peak current On/Off	35mA (230V) 75mA (110V) for 5ms	350mA for 5ms	350mA for 5ms
Consumption Failsafe	9.6W run, 0.12W hold	9.6W run, 0.85W hold	9.6W run, 0.85W hold
Peak current Failsafe	35mA (230V) 75mA (110V) for 5ms	350mA for 5ms	350mA for 5ms
Fuse On/Off	1A	2A	2A
Fuse Failsafe	5A	5A	5A
Maximum Break Torque	221 in./lbs.	221 in./lbs.	221 in./lbs.
Run & Reseat Torque	177 in./lbs.	177 in./lbs.	
Manual Operation	Yes, by hexagonal wrench (supplied in clip) when no power is being applied		
Run time On/Off	10-12 sec	10-12 sec	10-12 sec
Run time Failsafe	12-15 sec	12-15sec	12-15 sec

#### SMART FEATURES:

Operating frequency	Not continuous, 75% duty cycle but recommended to allow $\geq 1$ minute between cycles. DC uses Brushless Motor
Position Indication	Mechanically driven dome style visual 2 color indicator
Mounting restriction	None, can be mounted at any angle. Leave room for space to operate manually, and for electrical connection
End Position indication	Magnetic with digital sensing. No mechanical cams fitted.
ISO:5211	F03 & F05 (+ F04 which mounts at 45 degrees) with 14mm x 17mm deep female drive.
Working Angle	Factory set at $90^\circ \pm 2^\circ$ , maximum angle of rotation $360^\circ$
Smart Screen	1.3" Color OLED screen with touch buttons used for display and menu to customize functionality of actuator
Ingress protection	IP67
Max media temp	$\leq 176^\circ\text{F}$
Ambient temp	-4 to +140 °F (ABS) -4 to +176 °F (Aluminum) Non-operating temp ; $\leq -40\text{C}$ to $\geq 176^\circ\text{F}$
Cable Length	Flying lead 2.62 ft. as standard with 7 core cable 0.02 cm. voltage rated AC300V
Ambient humidity	5-95% RH non-condensing
Explosion proof	No, prohibited. Do not use in hazardous areas
Housing	Plastic (ABS)
Weight	With standard ABS housing 1.72 lbs. (With optional aluminum housing 2.16 lbs.)
Options	Extended flying lead option, per meter. Aluminum housing. Alarm output relays

#### Main Parts

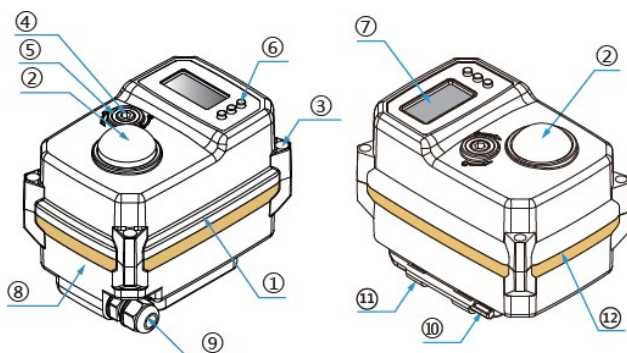

Item	Parts	Material
1	Actuator	ABS
2	Indicator	Transparent AS
3&4	Screw x 4 + Manual Shaft	304
5	Manual Override Seal	NBR
6	Push Buttons	Rubber
7	1.3" OLED Screen	OLED
8	Label	PVC
9	Allen Key for Manual Override	Steel
10	Weatherproof Cable Connector	Nylon
11	Cover Seal	NBR
12	Actuator	ABS

Just Ask DynaQuip: 800-545-3636 | [dynaquip.com](http://dynaquip.com)

# SV17 Wiring

## Standard Wiring for ON-OFF and Failsafe SV17 Actuators

Standard Wiring for our SV17 series actuators including all voltages, 12VDC, 24VAC/DC and 95-265VAC 50/60Hz. Our ON-OFF actuators use a simple 3 wire system for control and 3 wire feedback connection as below. Note that the internal space heater is pre-wired and doesn't require additional wiring. When the actuator is powered, the internal heater will operate.

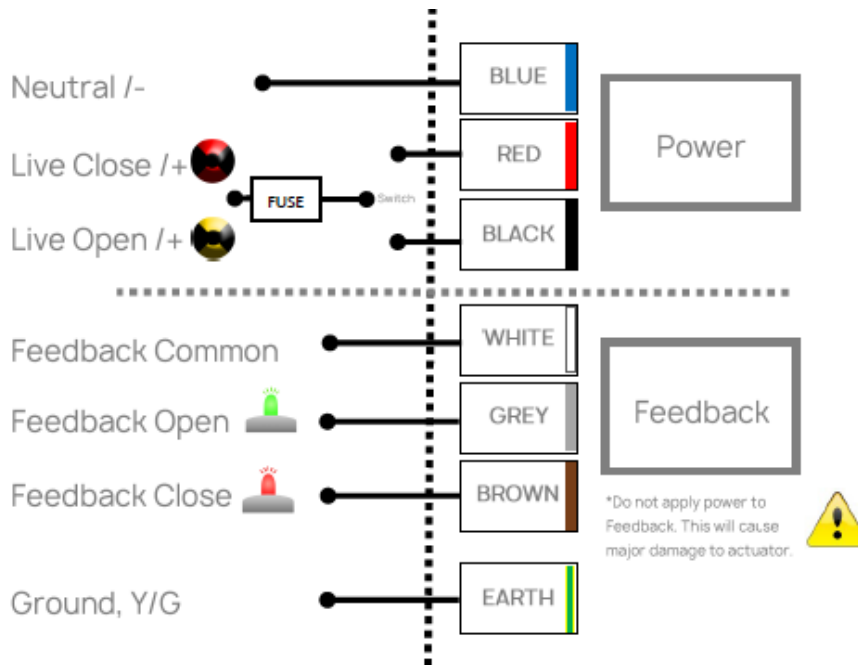

### Wiring Instructions:

1. Fuse: Please refer to the manual for more parameters.
2. SW switching capability: please refer to manual for more parameters.
3. Feedback signal contact load capacity: 0.1A/250VAC 0.5A/30VDC.
4. Please make sure actuator connect ground reliably.
- 5.

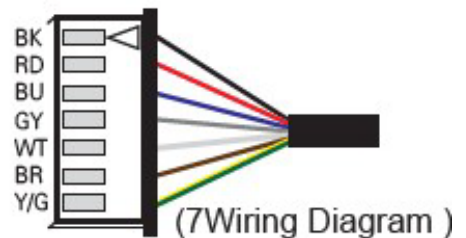

# DynaQuip SV17 Data Sheet Modulating

## Model: SV17 SMART MODULATING & SV17 MODULATING FAILSAFE ELECTRIC ACTUATORS

Specification	High Voltage	Low Voltage	
Rated Voltage	95-265VAC	24VAC/DC	DC12V
Voltage Range	AC 95-265V 50/60Hz DC 100-300V	AC 18-265V 50/60Hz, DC 2-23V	DC 22-32V
Consumption Modulating	9.6W run, 0.12W hold	9.6W run, 0.85W hold	9.6W run, 0.85W hold
Peak current Modulating	35mA (230V) 75mA (110V) for 5ms	350mA for 5ms	350mA for 5ms
Consumption Failsafe	9.6W run, 0.12W hold	9.6W run, 0.85W hold	9.6W run, 0.85W hold
Peak current Failsafe	35mA (230V) 75mA (110V) for 5ms	350mA for 5ms	350mA for 5ms
Fuse Modulating	1A	2A	2A
Fuse Failsafe	5A	5A	5A
Maximum Break Torque	221 in./lbs.	221 in./lbs.	221 in./lbs.
Run & Reseat Torque	177 in./lbs.	177 in./lbs.	
Manual Operation	Yes, by hexagonal wrench (supplied in clip) when no power is being applied		
Run time On/Off	10-12 sec	10-12 sec	10-12 sec
Run time Failsafe	12-15 sec	12-15 sec	12-15 sec

### SMART FEATURES:

Operating frequency	Not continuous, 75% duty cycle but recommended to allow $\geq 1$ minute between cycles. DC uses Brushless Motor
Position Indication	Mechanically driven dome style visual 2 color indicator
Mounting restriction	None, can be mounted at any angle. Leave room for space to operate manually, and for electrical connection
End Position indication	Magnetic with digital sensing. No mechanical cams fitted.
ISO:5211	F03 & F05 (+ F04 which mounts at 45 degrees) with 14mm x 17mm deep female drive.
Working Angle	Factory set at $90^\circ \pm 2^\circ$ , maximum angle of rotation $360^\circ$
Smart Screen	1.3" Color OLED screen with touch buttons used for display and menu to customize functionality of actuator
Ingress protection	IP67
Max media temp	$\leq 176^\circ\text{F}$
Ambient temp	-4 to +140 °F (ABS) -4 to +176 °F (Aluminum) Non-operating temp ; $\leq -40\text{C}$ to $\geq 176^\circ\text{F}$
Cable Length	Flying lead 2.62 ft. as standard with 7 core cable 0.02 cm. voltage rated AC300V
Ambient humidity	5-95% RH non-condensing
Explosion proof	No, prohibited. Do not use in hazardous areas
Housing	Plastic (ABS)
Weight	With standard ABS housing 1.72 lbs. (With optional aluminum housing 2.16 lbs.)
Options	Extended flying lead option, per meter. Aluminum housing. Alarm output relays

### Main Parts

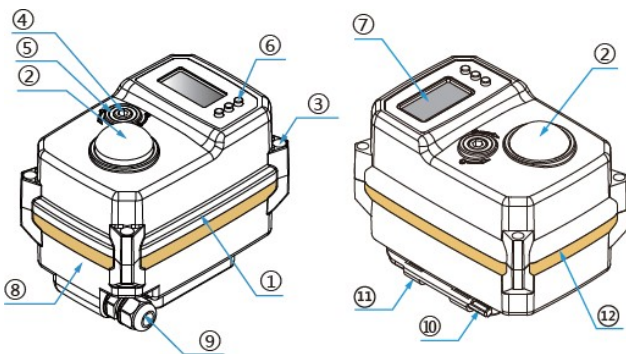

Item	Parts	Material
1	Actuator	ABS
2	Indicator	Transparent AS
3&4	Screw x 4 + Manual Shaft	304
5	Manual Override Seal	NBR
6	Push Buttons	Rubber
7	1.3" OLED Screen	OLED
8	Label	PVC
9	Allen Key for Manual Override	Steel
10	Weatherproof Cable Connector	Nylon
11	Cover Seal	NBR
12	Actuator	ABS

Just Ask DynaQuip: 800-545-3636 | [dynaquip.com](http://dynaquip.com)

## SV17 Wiring

### Standard Wiring for Modulating and Modulating Failsafe SV17 Actuators

Standard Wiring for our SV17 Smart series actuators including all voltages, 12VDC, 24VAC/DC and 95-265VAC 50/60Hz. Our ON-OFF actuators use a simple 2 wire system for power and 3 wire control and feedback connection as below and 3 wire input/output and common loop for modulating control. Note that the internal Space heater is pre-wired and doesn't require additional wiring. When the actuator is powered, the internal heater will operate

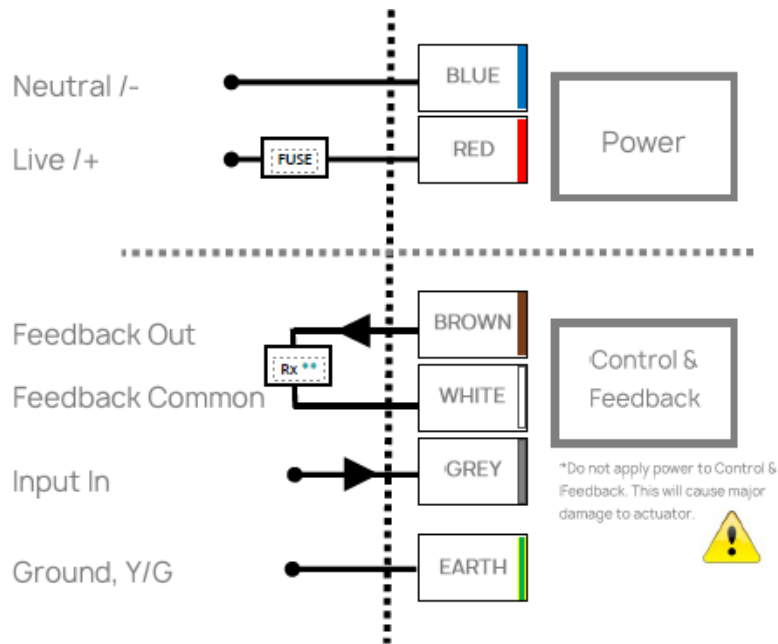

Note that Black is not used as standard unless Alarm Relay option is selected.

#### Wiring Instructions:

1. Fuse: Please refer to the manual for more parameters.
2. SW switching capability: please refer to manual for more parameters.
3. Feedback signal contact load capacity: 0.1A/250VAC 0.5A/30VDC.
4. Please make sure actuator connect ground reliably.

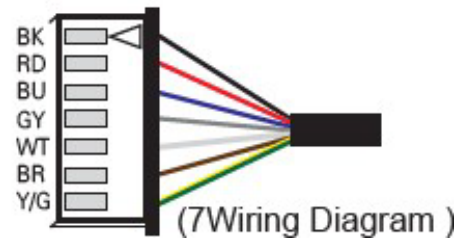

# DynaQuip SV17 Data Sheet On-Off and Hi Speed Modulating

## Model: SV17 SMART ON/OFF & SV17 Hi SPEED MODULATING ELECTRIC ACTUATORS

Specification	High Voltage	Low Voltage	
Rated Voltage	95-265VAC	24VAC/DC	DC12V
Voltage Range	AC 95-265V 50/60Hz DC 100-300V	AC 18-265V 50/60Hz, DC 2-23V	DC 22-32V
Consumption On/Off	9.6W run, 0.12W hold	9.6W run, 0.85W hold	9.6W run, 0.85W hold
Peak current On/Off	35mA (230V) 75mA (110V) for 5ms	350mA for 5ms	350mA for 5ms
Consumption Modulating	9.6W run, 0.12W hold	9.6W run, 0.85W hold	9.6W run, 0.85W hold
Peak current Modulating	35mA (230V) 75mA (110V) for 5ms	350mA for 5ms	350mA for 5ms
Fuse On/Off	1A	2A	2A
Fuse Failsafe	5A	5A	5A
Maximum Break Torque	177 in./lbs.	177 in./lbs.	177 in./lbs.
Run & Reseat Torque	177 in./lbs.	133 in./lbs.	
Manual Operation	Yes, by hexagonal wrench (supplied in clip) when no power is being applied		
Run time On/Off	5-6 sec	Std. 5-6 sec Hi-speed 1 sec	5-6 sec
Run time Failsafe	5-6 sec	5-6 sec	5-6 sec

### SMART FEATURES:

Operating frequency	Not continuous, 75% duty cycle but recommended to allow $\geq 1$ minute between cycles. DC uses Brushless Motor
Position Indication	Mechanically driven dome style visual 2 color indicator
Mounting restriction	None, can be mounted at any angle. Leave room for space to operate manually, and for electrical connection
End Position indication	Magnetic with digital sensing. No mechanical cams fitted.
ISO:5211	F03 & F05 (+ F04 which mounts at 45 degrees) with 14mm x 17mm deep female drive.
Working Angle	Factory set at $90^\circ \pm 2^\circ$ , maximum angle of rotation $360^\circ$
Smart Screen	1.3" Color OLED screen with touch buttons used for display and menu to customize functionality of actuator
Ingress protection	IP67
Max media temp	$\leq 176^\circ\text{F}$
Ambient temp	-4 to +140 °F (ABS) -4 to +176 °F (Aluminum) Non-operating temp ; $\leq -40\text{C}$ to $\geq 176^\circ\text{F}$
Cable Length	Flying lead 2.62 ft. as standard with 7 core cable 0.02 cm. voltage rated AC300V
Ambient humidity	5-95% RH non-condensing
Explosion proof	No, prohibited. Do not use in hazardous areas
Housing	Plastic (ABS)
Weight	With standard ABS housing 1.72 lbs. (With optional aluminum housing 2.16 lbs.)
Options	Extended flying lead option, per meter. Aluminum housing. Alarm output relays

### Main Parts

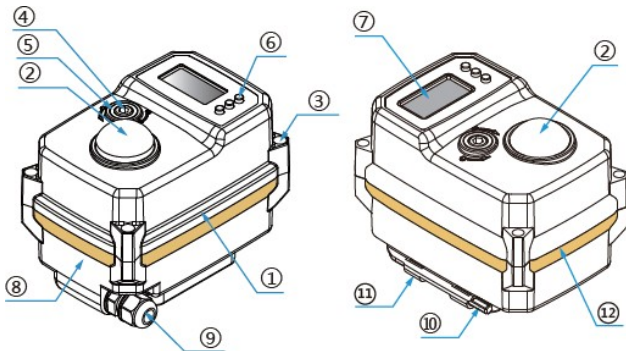

Item	Parts	Material
1	Actuator	ABS
2	Indicator	Transparent AS
3&4	Screw x 4 + Manual Shaft	304
5	Manual Override Seal	NBR
6	Push Buttons	Rubber
7	1.3" OLED Screen	OLED
8	Label	PVC
10	Allen Key for Manual Override	Steel
11	Weatherproof Cable Connector	Nylon
12	Cover Seal	NBR

Just Ask DynaQuip: 800-545-3636 | [dynaquip.com](http://dynaquip.com)

## SV17 Wiring Hi Speed On Off & Hi Speed Modulating

### Standard Wiring for Hi-Speed On/Off SV17 Actuators

Standard Wiring for our SV17 series actuators including all voltages, 12VDC, 24VAC/DC and 95-265VAC 50/60Hz. Our ON-OFF actuators use a simple 3 wire system for control and 3 wire feedback connection as below. Note that the internal Space heater is pre wired and doesn't require additional wiring. When the actuator is powered, the internal heater will operate.

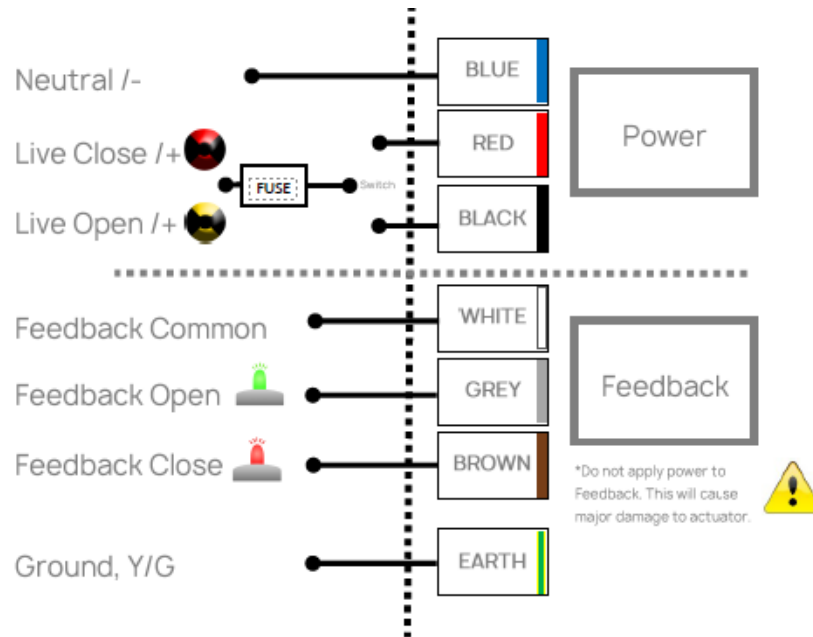

#### Wiring Instructions:

1. Fuse: Please refer to the manual for more parameters.
2. SW switching capability: please refer to manual for more parameters.
3. Feedback signal contact load capacity: 0.1A/250VAC 0.5A/30VDC.
4. Please make sure actuator connect ground reliably.

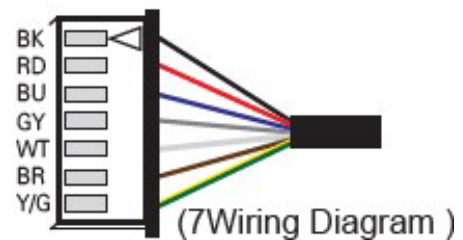

# SV17 Smart Actuator Menu and Screen Overview

## Introducing our Smart Screen and Menu Feature

All of our Smart actuators, Series SV17 are available, as standard with the color OLED screen and 3 button menu system as indicated in the image below. The screen will display as standard the input command that the actuator is receiving from its controller and the angle that it is currently at. The screen will also display any ALERT conditions such as an over torque condition or valve jam and will also indicate when power is lost where capacitor is fitted or control signal has been lost for modulating actuators.



## Local Control

All actuators come with Local Control to allow the actuator to be locally used to open and close via the touch buttons. When a modulating actuator is being used, you can use the open and close buttons to jog the actuator in small Incremental movements.



- M button is used to enter and switch menus.
- K2 is used in conjunction with K3 for adjusting values.
- K3 is used for changing settings, navigating menus, exiting and saving.
- OLED Screen with clear blue letters against a black background.

## Actuator Function Customization

The menu system will vary from actuator to actuator and we have specific actuator User Guides available for each actuator. Note that Firmware is updated from time to time to improve the performance and functionality of our actuators. As a result, the user guides can vary from the actuator you have. This is controlled via firmware versions. When powering the actuator or entering/exiting a menu, you can see the firmware version number. The menu functionality does vary but in general is used to make changes to the actuators standard functionality including working angle, speed control, 2 or 3 position setups, adjust opening and closing including setting of limit switches.

Position – Control Signal

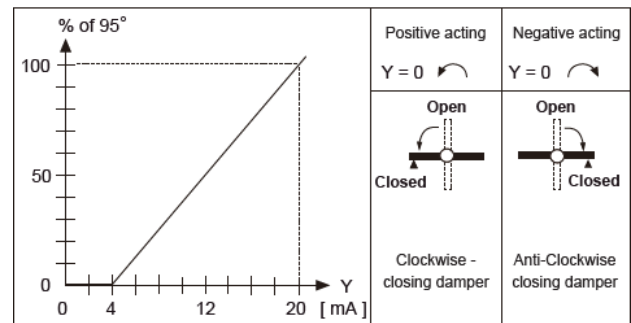

# DynaQuip SV17 Hi-Speed Manual

## SCREEN BY SCREEN USER GUIDE AND INSTRUCTION MANUAL FOR S2019 HI SPEED SERIES





- M Key: to switch menus
- K2 Key: to switch Flash Item or adjust values
- K3 Key: to modulate numerical value
- Screen 1.3"OLED,Blue word against black background, 128X64

Step	Menu Operation:- Manual Mode	
1	<p>Press and hold the K3 button, as shown above, for around 3 seconds. You will see K3 flashing in the top right-hand corner. The actuator is now in Manual mode. The actuator will now not respond to control signals from the PLC until taken out of Manual Mode. The actuator can be opened and closed as follows:</p> <p>Press K3 button, the actuator will OPEN</p> <p>Press K2 button, the actuator will CLOSE</p> <p>Press M button or without pressing any button for around 6 seconds, the actuator will exit Manual Mode.</p>	
2	<p>Long Press the M button, until you can see 'M' flashing in top right-hand corner. After around 3 seconds, enter user setting mode. The first screen you will see is dead zone setting.</p> <p>Dead zone setting main task is adjust the accuracy and sensitivity of the actuator. The adjustments are in degrees. The bigger the dead zone, the less accurate and sensitive the actuator is. The smaller the dead zone is the more accurate and sensitive the actuator is. The range is 0.3° to 3.9°, the system default is 1.0°.</p>	

Step	Menu Operation:- Dead zone setting	
3	<p>Long Press the M button, until you can see 'M' flashing in top right-hand corner. After around 3 seconds, enter user setting mode. The first screen you will see is dead zone setting.</p> <p>Dead zone setting main task is adjust the accuracy and sensitivity of the actuator. The adjustments are in degrees. The bigger the dead zone, the less accurate and sensitive the actuator is. The smaller the dead zone is the more accurate and sensitive the actuator is. The range is 0.3° to 3.9°, the system default is 1.0°.</p> <p>Press K3 button to increase the figure one by one</p> <p>Press K2 button to decrease the figure one by one</p> <p>Press M to enter next setting</p>	

# DynaQuip SV17 Hi-Speed Manual

Step	Menu Operation:- Slight adjustment to valve-off positon	
4	<p>Slight adjustment to valve-off position is to adjust the CLOSED position of the actuator. This is primarily used for where you want to allow for an inaccuracy between the valve stem and the actuator output drive. If the tolerance is not right, the actuator output drive can move a few degrees before it connects to the valve stem. This can mean that the actuator stops moving before the valve is in the fully closed position. This feature enables you to allow for this and effectively let the actuator over travel.</p> <ul style="list-style-type: none"> <li>Press K3 button to decrease 0.1° and the menu will show “Offset-Open” which indicates valve-off (CLOSE) position is moving towards the valve-on position (OPEN). If the menu shows “This is maximum”, which means the set value is out of range of valve-off limits.</li> <li>Press K2 button to increase 0.1° and the menu will show “Offset-Close” which indicates the actuator is moving towards valve-off position. If the menu shows “This is minimum” it means the set value is out of range of valve-off limits.</li> <li>Press M button to enter next setting.</li> </ul>	

Step	Menu Operation:- Control Command Exchange	
5	<p>Control command exchange: changing the setting to YES means that the valve –on (OPEN) command will now send the actuator to the valve-closed (CLOSED) position. Setting No means that the actuator will respond as normal.</p> <p>Press K3 to switch between Yes and No</p> <p>Press M button to enter next setting.</p>	

# DynaQuip SV17 Hi-Speed Manual

Step	Menu Operation:- B33 setting - to turn on B33 setting you need access code for Manage Mode.	
6	<p>B33 setting refers to the 3-position setup of the actuator. The actuator is capable of operating as 3 rotations of 90° allowing 3 position setups. Typically used on 3-way valves T port, 0°-90°-180°. The standard position is 50% to operate the actuator 0-90°. Increase the setting from 10% to 220%. Note that 220% is 180° position.</p> <p>Press K2 to decrease the value</p> <p>Press K3 to increase the value</p> <p>Press M to enter next setting.</p>	 <p>The image shows a close-up of the control panel's LCD screen. The screen displays 'UserSET:' followed by 'B33Pos: 50%'. To the right of the screen are three buttons labeled M, K2, and K3. Blue lines connect these buttons to the screen area.</p>

Step	Menu Operation:- Speed Control, running speed PULSE MODE	
7.1	<p>The running speed is the time it takes for the actuator to fully open or fully close. The run time is effected by the voltage of the actuator (see technical datasheets for more information) but this screen is used to slow down the running speed from the standard factory running speed. For Hi Speed please see Hi Speed series.</p> <p>The bigger the set value is, the shorter the switch time is. The smaller the value is set, the longer the switch time is. The range is 5%- 100%. The default is 100%, this will be the running speed set by factory and shown in datasheets.</p> <p>Press K3 button to increase by 5%.</p> <p>Press K2 button to decrease by 5%.</p> <p>Press M button to enter next setting item.</p> <p>PUL = PULSE—this means that the motor will receive short supply of voltage to achieve the desired working time. Motor will run stop run as per user setting to achieve the speed you need for open/close.</p> <p>Alternative option is PWM mode. See next page.</p>	 <p>The image contains three vertically stacked screenshots of the control panel's LCD screen. The top screen shows 'UserSET:' followed by 'Speed_PUL: XX%'. The middle screen shows 'UserSET:' followed by 'Speed_PUL: 100%' and 'This is maximum'. The bottom screen shows 'UserSET:' followed by 'Speed_PUL: 5%' and 'This is minimum'. Each screenshot has blue lines pointing to the M, K2, and K3 buttons on the right side of the panel.</p>

Step	Menu Operation:- Speed Control, running speed PWM MODE	
7.2	<p>The running speed is the time it takes for the actuator to fully open or fully close. The run time is effected by the voltage of the actuator (see technical datasheets for more information) but this screen is used to slow down the running speed from the standard factory running speed. For Hi Speed please see Hi Speed series.</p> <p>The bigger the value the faster the actuator will OPEN or CLOSE. The smaller the value is the slower the actuator will OPEN or CLOSE. The value range is 20% to 100%. The default is 100%.</p> <p>Press K2 to decrease the value</p> <p>Press K3 to increase the value</p> <p>Press M to enter next setting. Note that step 7 is Final step.</p> <p>PWM can impact the torque, contact technical support for more information.</p> <p>PWM = Pulse Width Modulating which is our alternative speed control method to PUL. PWM allows you to digitally set the working speed based on the angle of rotation as one continuous movement, rather than start, stop, start stop as the PULSE mode will.</p>	

Step	Exit Setup	
8	<p>This screen is the final screen you will see before returning to AUTO mode by saving changes and exiting or returning to screen 1. To save Press K3 and you will see the screen change to show software version, number of cycles and errors (note you won't see number of cycles on modulating actuators) and you will then be returned to the AUTO mode.</p>	

Step	FAULT / ALERT Conditions	
9	<p>The Smart series of AVA electric actuators have a number of displays that will occur under certain conditions. The actuators can detect certain errors or alarm conditions and display them on screen. The following Terminology is used to display the following faulty/conditions;</p> <ul style="list-style-type: none"> <li>• <b>NOCTRL</b> - This is referring to Modulating actuators and is advising the user that the actuator cannot see its digital input command. If using 4-20ma or 0—10V for example, check your supply and connection on the wiring of the actuator. Once the actuator can see the Control input signal again it will work as it should normally.</li> <li>• <b>PWRCUT</b> - For Failsafe actuators, the actuator can detect when power source (capacitor on 20 series or battery for 60/110 series) to open or close the actuator or stay put. Once power is restored the error message will disappear and the actuator will work as it should normally.</li> <li>• <b>ALERT</b> - There are 3 common conditions under which an ALERT will display. They are as follows;</li> </ul> <p><b>ALERT - Torque Limiter</b>, this will occur when the actuator experiences an over torque condition due to excessive torque in the valve. The actuator has a set maximum torque limiter and monitors an increase in current draw as an indicator or of an over torque situation. The other cause of the torque limiter to operate would be a valve jam. The actuator will stop to protect the gear-box, you can reverse the signal to see if this clears any valve jam. Reverse the signal once more to see the actuator stops in the same place it did previously. Once the jam is cleared of the valve torque issue is resolved, the actuator will work again and the ALERT screen will disappear.</p> <p><b>ALERT - Torque Limiter sensor failure</b> - note that there is a sensor monitoring current draw, if this hardware fails then it would replicate the same condition as a torque limiter issue without there being a torque issue. This is non re-pairable by the user and should be returned to the actuator. To check this, remove actuator from valve and test free of the valve. If ALERT displays re-turn to supplier.</p> <p><b>ALERT— Motor Failure</b>, this will occur if the motor within the actuator develop-ops a fault. This is not repairable by the user. It is identified by applying a control signal to the actuator, if the actuator does not move but you can hear the motor attempting to turn followed by an ALERT and the actuator is not fitted to a valve, this is a sign that the motor could have failed. Return to supplier.</p>	 <p>The images show the actuator's LCD screen displaying various fault messages. The top image shows 'NoCtrl', the middle image shows 'PwrCut', and the bottom image shows 'ALERT'. Each screen also displays 'UserSET: Speed_PWM: 100%'. The actuator has a 'M' button and directional arrows on the right side.</p>

# DynaQuip SV17 Modulating Manual





- M Key: to switch menus
- K2 Key: to switch Flash Item or adjust values
- K3 Key: to modulate numerical value
- Screen 1.3"OLED,Blue word against black background, 128X64

Step	Menu Operation:- Manual Mode
1	<p>Press and hold the K3 button, as shown above, for around 3 seconds. You will see K3 flashing in the top right-hand corner. The actuator is now in Manual mode. The actuator will now not respond to control signals from the PLC until taken out of Manual Mode. The actuator can be opened and closed as follows:</p> <p>Press K3 and the actuator will rotate in the anti-clockwise direction and the screen will show the current angle. The actuator will stop as soon as the button is released. If the angle is more than 90 degrees, the bottom screen will show 'Limit' and the actuator will now pass that point.</p> <p>Press K2 and the actuator will rotate in the anti-clockwise direction and the screen will show the current angle. The actuator will stop as soon as the button is released. If the angle is more than 90 degrees, the bottom screen will show 'Limit' and the actuator will now pass that point.</p> <p>Modulating local control differs to ON OFF and other models. Modulating is allowing you to JOG the actuator by small movements whereas an ON OFF actuator for example would just drive the actuator fully OPEN or FULLY close. The modulating version gives you 'fine' control.</p>



# DynaQuip SV17 Modulating Manual

Step	Menu Operation:- USER Setting Mode	
2	<p>Long Press the M button, until you can see 'M' flashing in top right-hand corner. After around 3 seconds, enter user setting mode. The first screen you will see is dead zone setting.</p> <p>Dead zone setting main task is adjust the accuracy and sensitivity of the actuator. The adjustments are in degrees. The bigger the dead zone, the less accurate and sensitive the actuator is. The smaller the dead zone is the more accurate and sensitive the actuator is. The range is 0.3° to 3.9°, the system default is 1.0°.</p>	
3	<p>To select direct acting or reverse acting.</p> <p>Direct acting means 4mA is closed and 20mA is open</p> <p>Reverse acting means 4mA is open and 20mA is closed.</p> <p>Press K3 button to switch positive acting and negative acting</p> <p>Press M to enter next setting</p>	

Step	Menu Operation:- No Control Command
4	<p>This is setting is to determine what the actuator should do on loss of control command. If no modulating signal is received the actuator can move the OPEN position, CLOSED position or KEEP its current position.</p> <p>Press K3 button to switch between 3 choices and shown on left.</p> <p>Once you have selected the position you want, press M to move to next screen.</p>



Step	Menu Operation:- Dead Zone Setting
5	<p>Dead Zone setting main task is to adjust the accuracy and the sensitivity, the unit of measurement is degrees. The bigger the dead zone is the less accurate the actuator is and the lower the dead zone is the more the accurate the actuator is. If too sensitive sometimes the actuator can have 'hunting issue' if input PLC is not as sensitive.</p> <p>Press K3 to increase 0.1</p> <p>Press K2 to decrease 0.1</p> <p>Press M to enter next setting.</p>

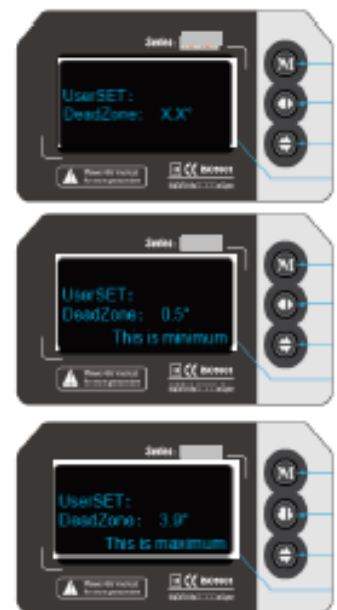

## DynaQuip SV17 Modulating Manual

Step	Menu Operation:- Slight adjustment to valve-off positon
6	<p>Slight adjustment to valve-off position is to adjust the CLOSED position of the actuator. This is primarily used for where you want to allow for an inaccuracy between the valve stem and the actuator output drive. If the tolerance is not right, the actuator output drive can move a few degrees before it connects to the valve stem. This can mean that the actuator stops moving before the valve is in the fully closed position. This feature enables you to allow for this and effectively let the actuator over travel.</p> <ul style="list-style-type: none"> <li>Press K3 button to decrease 0.1° and the menu will show “Offset-Open” which indicates valve-off (CLOSE) position is moving towards the valve-on position (OPEN). If the menu shows “This is maximum”, which means the set value is out of range of valve-off limits.</li> <li>Press K2 button to increase 0.1° and the menu will show “Offset-Close” which indicates the actuator is moving towards valve-off position. If the menu shows “This is minimum” it means the set value is out of range of valve-off limits.</li> <li>Press M button to enter next setting.</li> </ul>





Step	Menu Operation:- Out 4ma Modifying
7	<p>If 4mA deviation value of output current is big, user can adjust it by this screen. If the number increases, output current will be greater. If the number decreases then the output will be smaller.</p> <p>Press K3 to increase the figure one by one</p> <p>Press K2 to decrease the figure one by one</p> <p>Press M to access next screen.</p>



## DynaQuip SV17 Modulating Manual

Step	Menu Operation:- Out ma Modifying	
8	<p>If 20mA deviation value of output current is big, user can adjust it by this screen. If the number increases, output current will be greater. If the number decreases then the output will be smaller.</p> <p>Press K3 to increase the figure one by one</p> <p>Press K2 to decrease the figure one by one</p> <p>Press M to access next screen.</p>	

Step	Exit Setup	
9	<p>This screen is the final screen you will see before returning to AUTO mode by saving changes and exiting or returning to screen 1. To save Press K3 and you will see the screen change to show software version, number of cycles and errors (note you won't see number of cycles on modulating actuators) and you will then be returned to the AUTO mode.</p>	

Step	FAULT / ALERT Conditions	
10	<p>The Smart series of AVA electric actuators have a number of displays that will occur under certain conditions. The actuators can detect certain errors or alarm conditions and display them on screen. The following Terminology is used to display the following faulty/conditions;</p> <ul style="list-style-type: none"> <li>• <b>NOCTRL</b> - This is referring to Modulating actuators and is advising the user that the actuator cannot see its digital input command. If using 4-20ma or 0—10V for example, check your supply and connection on the wiring of the actuator. Once the actuator can see the Control input signal again it will work as it should normally.</li> <li>• <b>PWRCUT</b> - For Failsafe actuators, the actuator can detect when the power is removed. The actuator will use its alternative power source (capacitor on 20 series or battery for 60/110 series) to open or close the actuator or stay put. Once power is restored the error message will disappear and the actuator will work as it should normally.</li> <li>• <b>ALERT</b> - There are 3 common conditions under which an ALERT will display. They are as follows;</li> </ul> <p><b>ALERT - Torque Limiter</b>, this will occur when the actuator experiences an over torque condition due to excessive torque in the valve. The actuator has a set maximum torque limiter and monitors an increase in current draw as an indicator or of an over torque situation. The other cause of the torque limiter to operate would be a valve jam. The actuator will stop to protect the gear-box, you can reverse the signal to see if this clears any valve jam. Reverse the signal once more to see the actuator stops in the same place it did previously. Once the jam is cleared of the valve torque issue is resolved, the actuator will work again and the ALERT screen will disappear.</p> <p><b>ALERT - Torque Limiter sensor failure</b> - note that there is a sensor monitoring current draw, if this hardware fails then it would replicate the same condition as a torque limiter issue without there being a torque issue. This is non-repairable by the user and should be returned to the actuator. To check this remove actuator from valve and test free of the valve. If ALERT displays return to supplier.</p> <p><b>ALERT- Motor Failure</b>, this will occur if the motor within the actuator develops a fault. This is not repairable by the user. It is identified by applying a control signal to the actuator, if the actuator does not move but you can hear the motor attempting to turn followed by an ALERT and the actuator is not fitted to a valve, this is a sign that the motor could have failed. Return to supplier.</p>	 <p>The images show the actuator's LCD screen displaying various fault messages. The top image shows 'NoCtrl', the middle shows 'PwrCut', and the bottom shows 'ALERT'. Each screen also displays 'UserSET: Speed_PWM: 100%'. The actuator has a 'M' button and two arrow buttons on the right side.</p>