



UP Series Pneumatic Electric Actuator

Installation, Maintenance and Operational Manual



To order or for additional information, visit dynaquip.com or call 800-545-3636.

Pneumatic Actuator Engineering Manual

The actuator is designed for pneumatic operation with maximum air pressure of 120 PSIG and a temperature range of -4° to 176° F. The use of filtered and lubricated air is recommended.

WARNING

DO NOT APPLY ELECTRIC OR PNEUMATIC POWER UNLESS UNIT IS FULLY ASSEMBLED AND MOUNTED.

ALWAYS DISCONNECT ELECTRICAL AND PNEUMATIC POWER SOURCES AND RELIEVE PRESSURE IN THE SYSTEM BEFORE WORKING ON THIS UNIT.

IT IS RECOMMENDED THAT EYE PROTECTION BE WORN WHILE SERVICING THE SYSTEM.

FAILURE TO COMPLY WITH ABOVE WARNINGS COULD RESULT IN PERSONAL INJURY AND/OR DAMAGE TO THE UNIT.

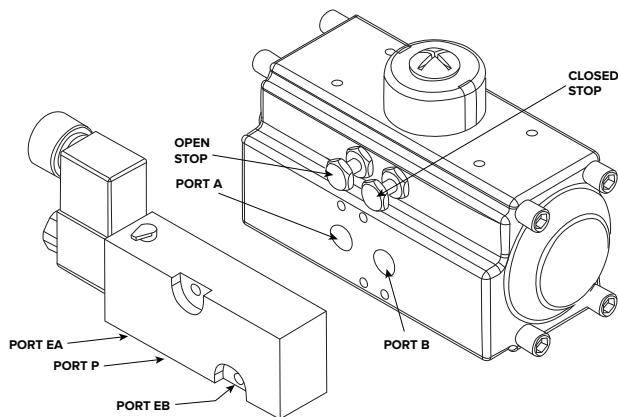

MOUNT SOLENOID IN POSITION SHOWN. USE THE TWO MOUNTING HOLES NOTED TO ALIGN O-RINGS AND SOLENOID TO THE ACTUATOR

Adjusting Stops

Adjust Open Position:

- Turn stop bolt CW to shorten stroke.
- Turn stop bolt CCW to lengthen stroke.

Adjust Closed Position:

- Turn stop bolt CW to shorten stroke.
- Turn stop bolt CCW to lengthen stroke.

Operation

Pressurizing port “A” will cause a counter-clockwise rotation of the shaft and position indicator. For double acting models, a clockwise rotation is obtained by pressurizing port “B” and venting port “A”. For spring return models, a clockwise rotation is obtained by removing supply air and venting port “A” only.

Actuators Equipped With Solenoid Valves

Double Acting (Normally Closed Mounting)

Air is supplied to the ¼" NPT port on the solenoid. When electric power is applied to the solenoid, air is allowed to enter the center chamber of the actuator, driving the pistons outward, causing a counter-clockwise rotation of the shaft. Air in the end chambers is vented to atmosphere. The actuator is in the open position.

When electric power is removed from the solenoid, supply air is shifted to the end chambers, driving the pistons inward, causing a clockwise rotation of the shaft. Air in the center chamber is vented to atmosphere. The actuator is in the closed position.

Spring Return (Fail-Safe Closed Mounting)

Air is supplied to the ¼" NPT port on the solenoid. When electric power is applied to the solenoid, air is allowed to enter the center chamber of the actuator, driving the pistons outward, compressing the springs in the end chambers and causing a counter-clockwise rotation of the shaft. Air in the end chambers is vented to atmosphere. The actuator is in the open position.

When electric power is removed from the solenoid, supply air is blocked and air in the center chamber is vented to atmosphere. The compressed springs in the end chambers extend, driving the pistons inward, causing a clockwise rotation of the shaft. The valve is in the closed position.

Fail-Safe Features

When electrical failure occurs and the air supply is not interrupted, the solenoid on the double acting model will cycle the actuator to the closed position.

Spring return model actuator will cycle to the closed position in the event of electrical and/or air supply failure.

Valve being actuated can be mounted to the actuator in such a way that the valve can either fail-safe open or fail-safe closed.

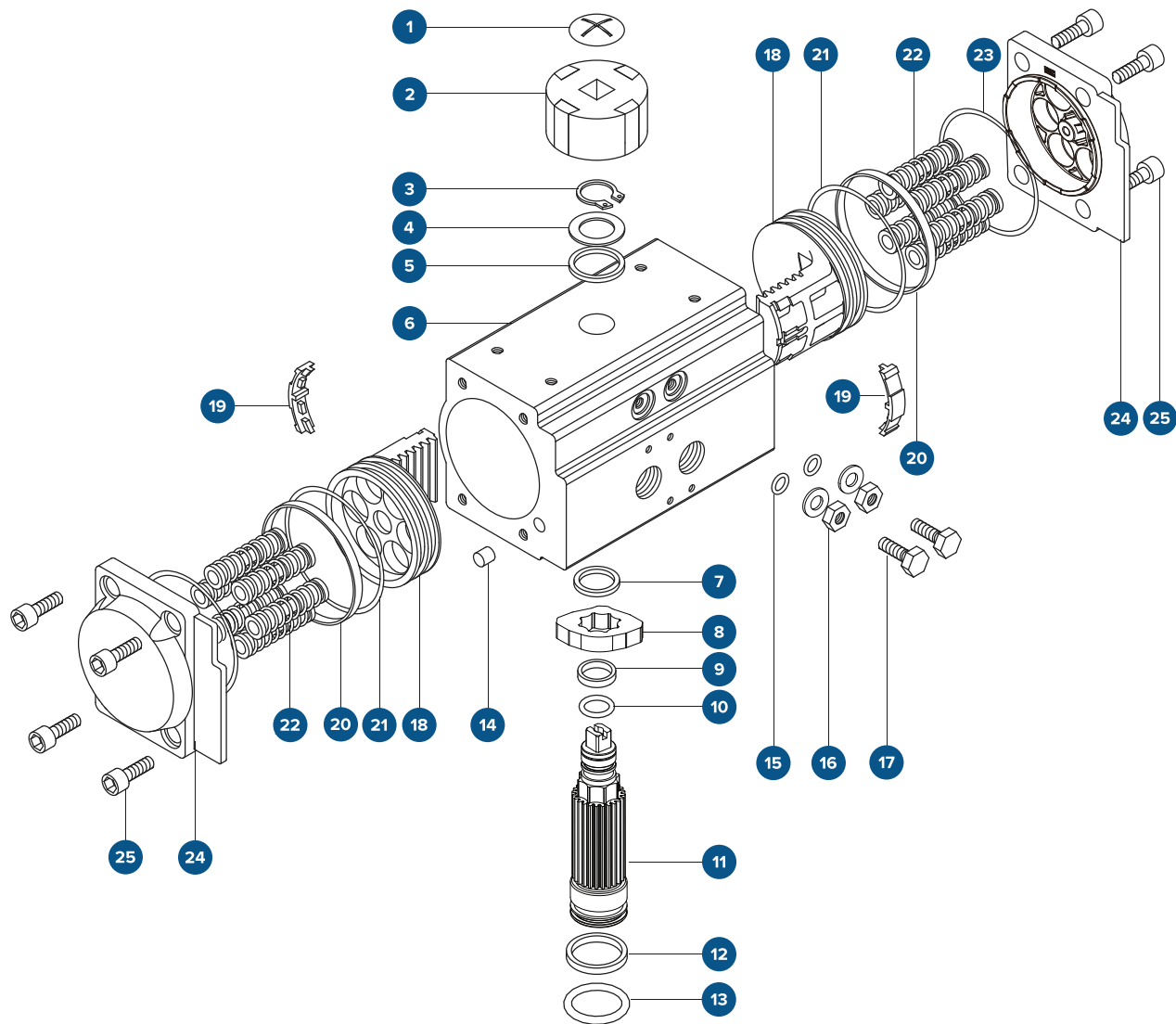

Manual Override

In the event of air pressure failure, the actuator may be cycled manually. This is done by removing the position indicator and applying a wrench to the exposed end of the shaft and turning it in the desired direction.

For manual operation, the air must be allowed to escape from the actuator. This may require disconnecting air lines at the actuator or solenoid inlet port.

Cycle Check

A routine cycle check can be performed on actuators equipped with supplied solenoids, by activating the override button on the solenoid body.

Maintenance

Under normal operation, pneumatic actuators require no formal maintenance program. Regularly scheduled inspections should be performed to check:

- Actuator-to-valve alignment
- Damaged housing or mounting hardware
- Worn, loose or shifted parts due to shock, vibration etc.

See page 4 for Troubleshooting.

Repair Kits

Repair kits include item numbers 3, 4, 5, 7, 9, 10, 12, 13, 14, 15, 19, 20, 21 and 23. Use the actuator base model number followed by RK. e.g. UP048RK. To order replacement springs use the actuator base model number followed by SPRG. e.g. UP048SPRG. (sold individually)

NO.	DESCRIPTION	QUANTITY	STANDARD MATERIAL	PROTECTION
1	Indicator Screw	1	ABS + Stainless Steel	
2	Indicator	1	Plastic	
3	Spring Clip	1	Stainless Steel	
4	Thrust Washer	1	Stainless Steel	
5	Outside Washer	1	Delrin	
6	Body	1	Extruded Aluminum Alloy	Hard Anodized
7	Inside Washer	1	Delrin	
8	Cam	1	Alloy Steel	
9	Bearing (Pinion Top)	1	Delrin	
10	O-Ring (Pinion Top)	1	Delrin	
11	Pinion	1	Alloy Steel	Nickel Plated
12	Bearing (Pinion Bottom)	1	Delrin	
13	O-Ring (Pinion Bottom)	1	NBR	
14	Plug	2	NBR	
15	O-Ring (Adjust Screw)	2	NBR	
16	Nut (Adjust Screw + Gasket)	4	Stainless Steel	
17	Adjust Screw	2	Stainless Steel	
18	Piston	2	Cast Aluminum/Casting	Anodized
19	Guide (Piston)	2	Delrin	
20	Bearing (Piston)	2	Delrin	
21	O-Ring (Piston)	2	NBR	
22	Spring	0-12	Spring Steel	Electrophoretic Paint
23	O-Ring (End Cap)	2	NBR	
24	End Cap	2	Cast Aluminum	Powder Polyester Painted
25	Cap Screw	8	Stainless Steel	

Troubleshooting

SYMPTOM	POSSIBLE PROBLEM	POSSIBLE SOLUTION
Actuator does not respond to control signal	Power interruption (electric)	Check supply power for proper voltage
	Power interruption (air)	Check air supply pressure
Actuator will not fully open and/or close the valve	Travel limit set improperly	Set internal and/or external stops
	Valve torque too high	Check valve for blockage or other malfunction Check to assure proper sizing of actuator to valve torque
Erratic operation	Over heating due to excessive cycle rate	Rapid and continuous cycling will cause heat build-up and seal failure. Reduce cycle rate
Actuator operates but valve does not turn	Broken linkage	Check linkage between actuator and valve
	Broken valve stem	Check valve stem

To order or for additional information, visit dynaquip.com or call 800-545-3636.